

**FLYER**

# Noble Pro

**NB4 Pro**

**2.4GHz  
AFHDS 3**

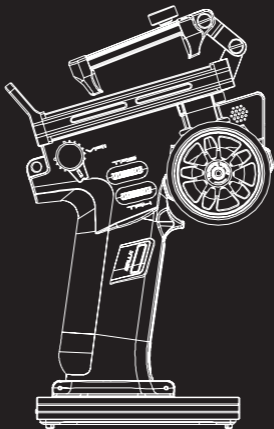

# Quick Start Guide

## **Precaution !**

For your own safety: make sure to download and read the Disclaimer & Warning documentation from the Flysky website before using this product.

Flysky Website: [www.flysky-cn.com](http://www.flysky-cn.com)

1. The ce warns that the installation of the antenna used in this transmitter must be kept in distance from all the personnel and shall not be used or used with any other transmitter. The end user and the installer must provide antenna installation instructions and transmitter operating conditions to meet the requirements for rf exposure compliance.
2. Hereby, [ShenZhen FLYSKY Technology Co., Ltd.] declares the RF equipment [Noble Pro (NB4 Pro), FG4 Pro] to be in accordance with RED2014/53/EU.
3. The full text of the EU DoC is available at: [www.flyskytech.com/info\\_detail/10.htm](http://www.flyskytech.com/info_detail/10.htm)

## Transmitter Overview

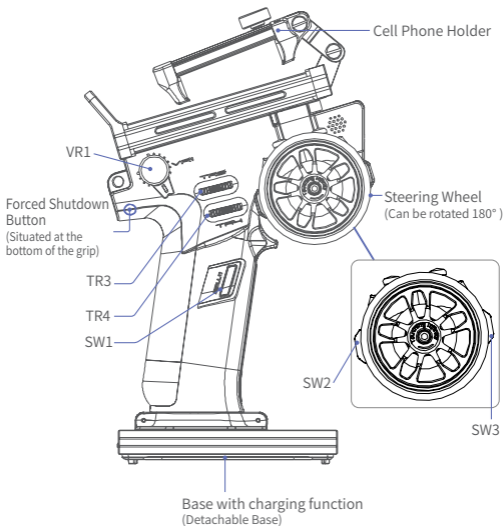

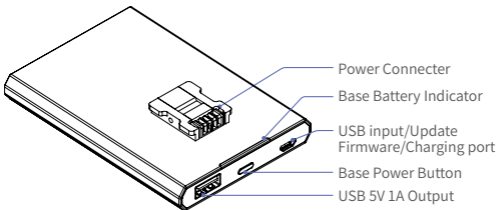
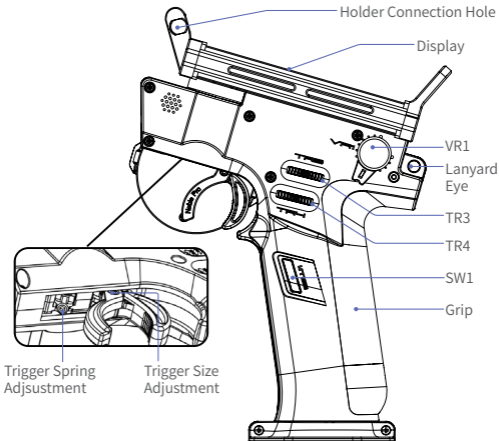

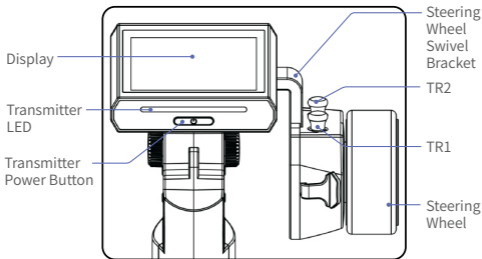

Adjust the Length of the Cell Phone Holder

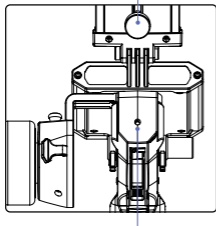

Adjust Trigger stroke length

Adjust Steering Wheel Stiffness

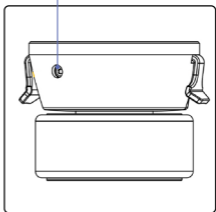

- For more information about the transmitter, please refer to the user manual.

## Detachable Base

The transmitter base is a removeable base.

Base power button: press for a short time to charge the battery at the transmitter handle and to charge external devices. Press for 2 seconds to turn off the output of the power supply.

When the transmitter needs to be charged or when charging the base, plug in the micro USB cable and charge it through the USB port located on the base.

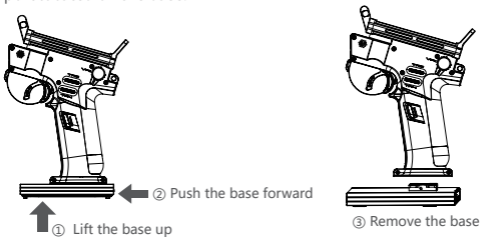

**!** Note: The NB4 pro should not be charged during use!

## Charging Mode

There are two charging modes for NB4 pro, one is by connecting the USB cable, the other is by wireless charging. When the battery is fully charged, the 4 LEDs on the base are solid on.

### **Wireless Charging**

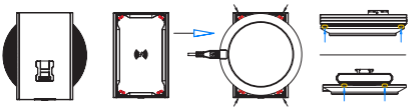

- The four bumps of the transmitter base should be connected to the base of the wireless charging transmitter.
- When the transmitter base indicator of the wireless charger is blue, it indicates the connection is successful and there is ongoing charging.
- When the transmitter base indicator of the wireless charger is red, it indicates the transmitter base is not connected, or the connection failed.

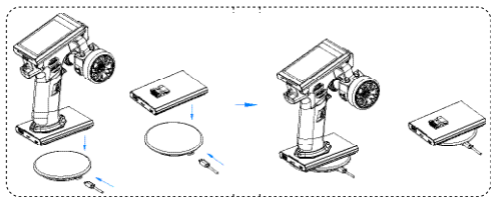

When the transmitter base indicator of the wireless charger is blue and solid on, it indicates that the battery is fully charged. It takes about 8.5 hours to fully charge in the entire system (including the transmitter, base, and wireless charger base).

**!** If the transmitter base of the wireless charger is not used properly, it will lead to ineffective charging, or the charging efficiency may be affected.

There are the following non-standard operations: transmitter base is not aligned with the wireless charger base, the base may be tilted, or the four bumps are not connected to the base.

#### Notes:

1. In order to prolong the service life of the battery, don't to fully charge it for a long time, and it should be properly discharged, and charge it regularly to prevent damage to the battery from over-discharge. It is recommended that the storage voltage of battery is

about 3.80~3.90V in case of preservation.

2. Please use the micro USB cable shipped with this transmitter to charge it. Improper use may cause charging failure.

3. Do not charge the transmitter and external devices at the same time, otherwise it may affect the transmitter's charging saturation time, even when the external equipment load is too large, the overload protection will be triggered.

## Powering On

To power on the transmitter.

### Setup:

1. Before use make sure that the battery is fully charged.
2. Press and hold the transmitter power button until the screen turns on.
  - After power-on, the system will pop up a window to prompt whether to set up failsafe for the current model. To disable the failsafe setting prompt, tap [NO] or turn off the [Failsafe Warning] via [SYSTEM].

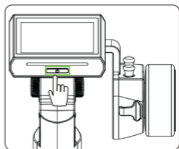

## Powering Off

To power off the transmitter.

### Setup:

1. Disconnect the receiver from its power supply.
  2. Press and hold the transmitter's power button until the screen powers off.
- !** Always power off the receiver before the transmitter, failure to do so can result out of control. Unreasonable setting of the Failsafe may cause accidents.



## LED Indicator

The NB4 pro has 2 status indicators, one below the screen is on the top of the transmitter and one is located at the detachable base.

### **Transmitter LED**

The LED can be set to five different colors: red, green, blue, yellow and white. You can also turn the LED off completely.

Setup:

1. Touch the function menu icon , then touch the [System] icon and navigate to LED;
2. Touch [LED];
3. Select a color by touching it.  indicates the color is selected and it will be updated in real time.
4. Press  to save and exit.

### **Base Battery Indicator**

The Base Battery Indicator has 4 LEDs and is mainly used to display bases battery level.

When the base battery voltage is low, the base LED will only have one LED light on and start flashing.

When charging the LED will flash and the amount of active LEDs will increase as the battery charges.

## Failsafe

This function protects the user by preventing the model from behaving unexpectedly if signal is lost.

For the failsafe function, the system provides the following configuration options:



- Set the failsafe judgment time.

- Disable i-BUS-out and PPM protocol signal output in case of out-of-control: When the failsafe is triggered, the i-BUS-out and PPM connectors will have no output.
- Configure failsafe settings per channel: Each channel can be individually set to one of four modes: [Not Set (No Output)], [Channel Value None Output], [Fixed Value], or [Hold].
- [Set All Fixed Value]: In case of out-of-control, all channels configured with a fixed value will output their current values.
- Test the failsafe function: Simulate a signal loss scenario where the transmitter disables RF output, and the model enters failsafe mode. All channels will output according to the configured failsafe settings.

## Failsafe Test Function

To simulate that after the model is out-of-control, the transmitter will turn off the RF output, and the model will enter the failsafe status, and all channels will be output according to the failsafe settings.

Setup:

1. Tap , a popup window comes along with it as shown. Press and hold  over 1 second, then the system turns off RF. And the receiver output channel value according to failsafe settings.
2. Release , the RF will be on and the connection will be restored.

## Failsafe Judgment Time

Used to set the failsafe judgment time, the setting range is from 250ms to 1000ms. By default, it is 300ms.

Setup:

1. Tap [Judgment Time] to enter the setting interface.
2. Click +/- to set the appropriate value, then click  to return.

## i-BUS & PPM Signal no Output

This function is for i-BUS and PPM signals. After the [i-BUS & PPM signal no output] is enabled, regardless of the setting of the failsafe, these two types of failsafe signals are always no output. By default, the system is in the enabled status.

Tap  at the right side of [[i-BUS/PPM No Output], the check box next to right of the option is not ticked, it indicates that the function is disabled.

## Setting A Separate Channel

Used to set the output signal states of channels respectively: [Not set (No output)] means the failsafe of this channel has not been set, and there is no output in case of out-of-control. [Channel Value None Output] means that there is no output in case of out-of-control; [Hold] means the last channel value is kept in case of out-of-control; [Fixed Value] means that you can set the failsafe output value by moving the control, then the value set will output in case of out-of-control.

Setup:

1. Tap the channel you want to set.
2. Click an appropriate option as desired. If the fixed value is selected, move throttle trigger (steering wheel, button or knob) to the desired position and hold it, then click  to finish the settings.

## Setting All Fixed Value Channels

Used to set the output value of all channels that have been set to a fixed value after out-of-control.

Tap this function while moving the control to the desired position and holding, after that a prompt interface comes along with it. Click "YES" to finish.



### Attention

- For safety, it is recommended that all users pre-set this function before use.



## Servos Frequency

This function is used to adjust the servo control frequency. This function can be used for analog servos (95Hz), digital servos (380Hz) and can also be set to custom. Digital servos and custom frequencies range between 50-400Hz.

The servos frequency varies slightly with the connected receivers.

### For the Classic Version Receiver

Setup:

1. Click [Servos Frequency].
2. Click the corresponding option. Click  to return to the previous level interface.
  - If the transmitter RF Setting is set to [AFHDS 3 1 way], modify the servo response speed and then tap . The system prompts "It takes effect after bind or re-bind. Are you sure you want to bind?"
3. If you choose [Custom], click "+" or "-" to adjust the frequency.

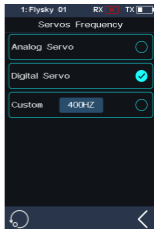

### For the Enhanced Version Receiver

[SR] One of the specifications in the servos speed (PWM frequency is 833 Hz).

[SFR] One of the specifications in the servos speed (PWM frequency is 1000 Hz).

[Synchronized with RF] The PWM output is synchronized with the timing of the (RF) radio signal reception.

Note: The conventional servos speed (PWM frequency) is 50-400 Hz. The overall system delay will be decreased when SR and SFR



are selected. Make sure that the adapted servo supports the corresponding frequency. Otherwise, it may cause the servo not to work properly or even damage the servo.

## Setting A Channel

Sets PWM frequency for a channel.

Setup:

1. Click [Servos Frequency].
2. Click [Steering: Digital Servo] or other options to enter.
  - Click the check box on the right of [Synchronized with RF]. The icon will change to . The servo frequency of this function will be synchronized to RF after it is checked.
3. Click the right side of the corresponding servospeed according to the actual state of the adapted receiver. Click  to return to the previous menu.

## Setting All Channels

Sets PWM frequency for all channels

For function Setup, refer to the Setup section of Setting A channel above.



**Both the analog servos (95Hz) and the digital servos (380Hz) are common servo frequencies and as such, are available as presets for quick setup. In order for servos to operate normally they must receive the correct frequency, to find the frequency refer to the servos' user manual.**

## Firmware Update

The firmware of the transmitter can be updated by connecting to a Windows computer using a micro USB cable. Once this function is activated, all transmitter functions will stop working. To prevent the vehicle from losing control, power off the receiver before attempting to use this function.



### Warning

- Use the micro USB cable provided.
- Do not disconnect the micro USB cable while the firmware is being updated!
- When the computer can not recognize the transmitter, check whether the base is well conected.

### How to Update:

1. Download and open the latest official firmware;
2. Connect the transmitter to the computer via the micro USB cable first;
3. Click  in the main interface to enter the function menu and select [SYSTEM];
4. Touch [Firmware Update]. The system will display the warning: "Updating the transmitter firmware may cause model data to be restored to factory defaults. Are you sure?", touch [YES] to continue.
5. After completing the above steps, the computer update software window pops up, click [Update] to start the update.
6. Once the update is complete, the transmitter will exit the update status automatically and reboot. (It is now safe to remove the micro USB cable. And close the firmware wizard.)



### Attention

- After a firmware update the receiver may not be connected. If this is the case the RF module and receiver need to be updated.

## RF Module Firmware Update

### How To Update:

1. Click  in the main interface to enter the function menu.

2. Select [MODEL], and navigate to then touch [Radio Frequency Setup]. Then touch [Update RF]. The system will prompts "The RF firmware will be updated. Are You Sure?", select [YES] to continue. The transmitter will exit the RF update status automatically when the update is finished.

Note: If the transmitter can not enter the RF updating status, there is probably no RF module or the RF module doesn't work.

## Updating Receiver Firmware

Update the firmware of the receiver by the transmitter which has bound with the receiver and has the built-in firmware of the receiver. You can also update it by FlyskyAssistant that establishes a connection with the transmitter.

Setup:

1. Click [Update Receiver]
2. Select an appropriate receiver, then click [Update]. When the progress is 100%, it indicates the update is successful.

Notes:

1. Some receivers such as GMr need to be updated by "Flysky Assistant", Download "Flysky Assistant" via Flysky official website.
2. Make sure the transmitter and receiver are bound. Navigate to [Receiver Setting], click [Update Receiver], the system will then display a prompt "Update receiver, are you sure?". Touch "YES" to update.
3. If the receiver is not bound or connected to the transmitter the transmitter will display the prompt "Please connect XXX or enable XXX to enter the mandatory update mode". Touch [OK] to enter updating status.

While updating the firmware of the receiver, the transmitter is

unable to bind with the receiver, the receiver need to update the firmware mandatorily.

There are two methods to let the receiver into forced update mode:

- Power on the receiver while pressing the BIND button for more than ten seconds, the LED is in a state of three-flash-one-off, then release the BIND button.
- Power on the receiver first, then press and hold the BIND button for more than 10 seconds, the LED of the receiver will be in a state of three-flash-one-off, then release the BIND button.

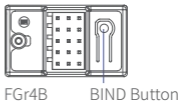
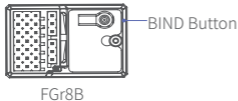

Note: Different receivers may have different ways of entering the firmware update status. Please refer to the instructions of related receivers in the website.

## Binding

The transmitter and receiver have already been pre-bound at the factory, however if you wish to bind again or bind a new receiver follow the steps below:

1. Turn on the transmitter. Click  in the main interface to enter and navigate to [RX SET], then select [Bind Set]. Choose [Classic Rx] or [Enhanced Rx] according to your real receiver.(If two receivers are used, click the check box on the right side of [Two Rx Mode], then set the start channel), then touch [Start Bind] to put the transmitter to enter binding mode.
2. Put the receiver to enter binding mode.

3. The binding process is complete when the LED of the receiver stops flashing and is solid on.
4. Check to make sure the transmitter and receiver functions are working correctly, repeat steps 1 to 3 (binding process) if any problems arise.

#### **Notes:**

1. When you choose one-way communication, the receiver does not send the data to the transmitter, the indicator flashes slowly after the receiver receives the binding information. After the receiver LED becomes slow flashing, then put the transmitter to exit the binding state. When the LED of the receiver is solid on, indicating the success of the binding.
  2. Flysky AFHDS 3 classic version receiver models: FTr10/FGr4/FGr4S/FGr4P/FTr4/FTr16S. Other Flysky AFHDS 3 receivers are enhanced version receivers.
  3. If you want to use the dual receiver mode, click the check box on the right side of [Two Rx Mode]. The icon will change to  and then the transmitter will enter dual receiver mode. After selection, bind the transmitter with the primary receiver and the secondary receiver in turn.
- These steps are only for the Noble NB4 Pro transmitter in use with the FGr4B receiver and the FGr8B receiver. If you are using other receivers please visit the website for more information.

## Specifications

### **Noble Pro(NB4 Pro)**

Compatible RC Models	Cars/Boats/Robots/Ironclads
Number of Channels	It can be selected: 2(Extreme-speed), 4, 6, 8, 10, 12 or 18 channels
RF	2.4GHz ISM
Maximum Power	< 20 dBm (e.i.r.p.) (EU)
RF Protocol	AFHDS 3
Low Voltage Alarm	< 3.65V
Data Interface	Micro USB
Charging Jack	Micro USB + Wireless Charging
Antenna	Built-in Single Antenna
Input Power	1S/4.2V Lithium Battery + 18650 Dual-Battery
Firmware Update	Supported
Distance	> 300m( Without stand)
Dimensions	120*144*274mm
Weight	670g ( With Cell Phone Holder)
Certifications	CE, FCC ID: N4ZFG400, MIC, RCM

## 注意事项！

开始使用前请务必在 Flysky 官网下载并阅读《免责声明 & 警告》了解安全注意事项，并在 Flysky 官网下载阅读使用说明书。

Flysky 官网地址：[www.flyskytech.com](http://www.flyskytech.com)

1. 本发射机所用天线的安装必须与所有人员保持距离，不得与任何其他发射机共用或一起使用。必须向最终用户和安装人员提供天线安装说明和发射机操作条件，以满足射频暴露合规要求。
2. 特此，【ShenZhen FLYSKY Technology Co., Ltd.】声明无线电设备【Noble Pro(NB4 Pro), FG4 Pro】符合 RED2014/53/EU.
3. 欧盟 DoC 声明全文可在以下互联网地址 [www.flyskytech.com/info\\_detail/10.htm](http://www.flyskytech.com/info_detail/10.htm) 获取。

## 发射机概览

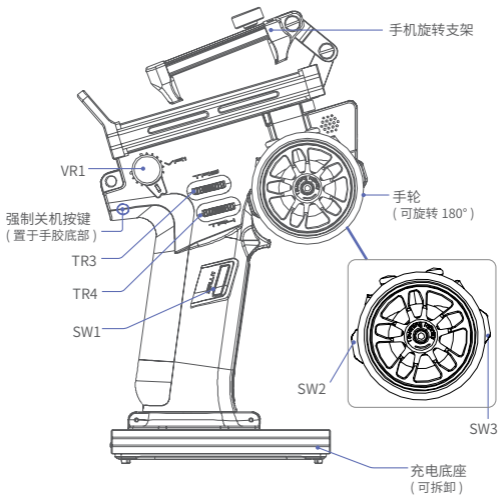

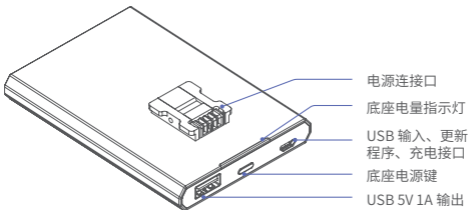
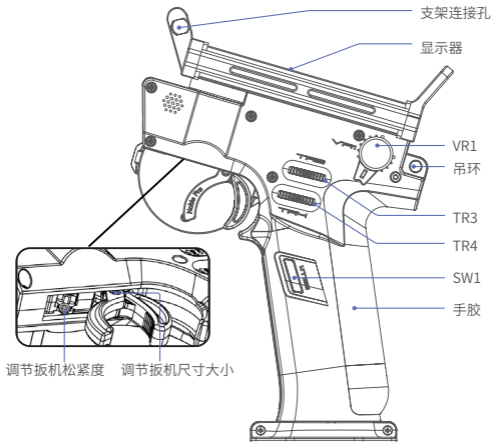

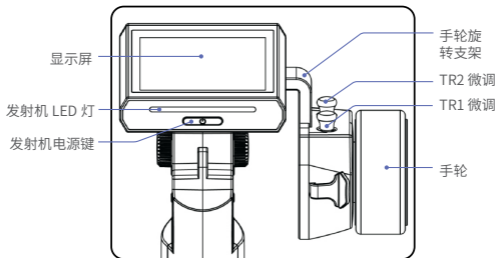

调节手机支架长短

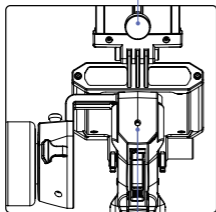

调节手轮松紧度

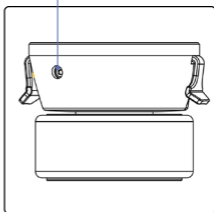

调节整个扳机结构行程

- 关于 Noble Pro 发射机的更多操作请阅读使用说明书。

## 发射机底座

发射机底座可拆卸。

按下底座电源键，底座电量指示灯亮起，即给发射机充电或 USB 输出端口输出 5V 电压，可给外部设备充电。再次长按底座电源键，底座电量指示灯灭，同时停止充电。

当发射机需要充电时，通过底座 USB 输入端，连接 Micro USB 数据线即可充电。

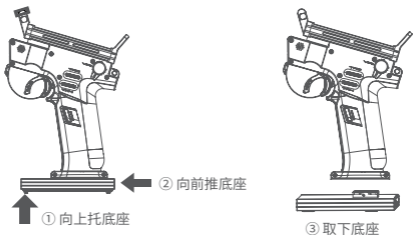

**!** 请勿同时给发射机及外部设备充电，否则可能影响发射机充电饱和时间，甚至外部设备负载过大时，会触发过载保护。

## 充电

Noble Pro 发射机有两种充电方式：Micro USB 线插入充电口充电或使用无线充电底座对其进行充电。电量充满后底座 4 颗灯常亮。

### 无线充电

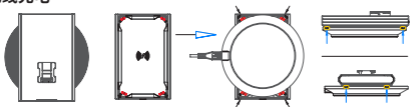

- 发射机底座的四个凸点要卡住无线充发射端底座。
- 无线充发射端底座指示灯呈蓝色表示连接成功正在充电。
- 无线充发射端底座指示灯呈红色表示未连接发射机底座或连接不规范。

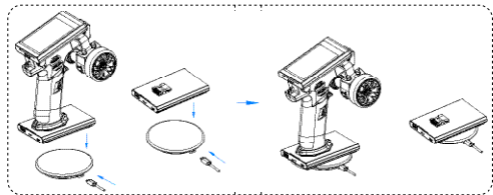

无线充发射端底座指示灯呈蓝色常亮表示电量已经充满。整机（含发射机和发射机底座以及无线充发射端底座）充满电量时间约 8.5 小时。

**!** 如果无线充发射端底座使用不规范会导致充电无效，甚至有损充电效率。

发射机底座未与无线充底座对齐、放置倾斜或四个凸点未卡住地盘都属于不规范操作。

注：

- 为延长电池使用寿命，长时间放置请注意不要满电，应适当放电后再进行放置，并且应定期充电防止电池过放损坏；建议电池保存电压为 3.8~3.9V。
- 请使用本款发射机标配的 Micro USB 数据线对其进行充电，使用不当则可能导致充电失败。
- 请勿同时给发射机及外部设备充电，否则可能影响发射机充电饱和时间，甚至外部设备负载过大时会触发过载保护。

## 开机

开启 Noble Pro 发射机。

功能设置：

1. 检查系统状态，确保电池电量充足；
2. 长按发射机电源键，直至屏幕亮起，表示开机。
  - 开机后，系统会弹窗提示当前模型是否设置失控保护。若要关闭失控保护设置提示，则点击 [ 否 ] 或通过 [ 系统设置 ] 关闭“失控保护提示”。

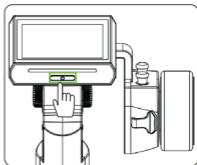

## 关机

关闭 Noble Pro 发射机。

功能设置：

1. 断开接收机电源；
2. 长按发射机电源键，直至屏幕熄灭，表示关机。

**!** 关闭前，请务必先断开接收机电源，然后关闭发射机。如果强行关闭发射机，将会导致遥控设备失控。失控保护设置不合理可能引起事故。

## LED 指示灯

Noble Pro 有两种 LED 指示灯，分别是发射机 LED 灯、底座电量指示灯。

### 发射机 LED 灯

有五种颜色，分别为红色、绿色、蓝色、黄色、白色，也可以关闭 LED 灯显示。

功能设置：

1. 点击主界面  进入功能菜单界面，选择进入 [ 系统设置 ]；

2. 点击 [LED]，进入设置界面；
3. 根据需要选择颜色，点击 ，显示  表示选择成功，同时发射机 LED 指示灯会显示对应颜色。
4. 设置完成后点击 ，即可退出。

## 底座电量指示灯

由四个 LED 灯组成，主要用于显示底座的电池电量。

当底座电量低时底座 LED 灯将会仅有一个 LED 灯亮同时闪烁；当底座正在充电时，LED 灯将会闪烁，同时按照实际电量 LED 灯灯亮个数也会变化。

## 失控保护

失控保护功能用于在接收机失去信号不受控制后，接收机按预设方式进行输出，保护模型及人员安全。



对于失控保护功能，本系统提供了如下的设置方式：

- 设置失控保护判断时间。
- 设置失控时关闭 i-BUS-out 和 PPM 协议接口信号输出，即失控时 i-BUS-out&PPM 接口为无输出状态。
- 按通道设置，即每一个通道设置一个失控保护数值，可设为 4 种模式，[ 未设置（无输出）]、[ 通道值无输出 ]、[ 固定值 ] 或 [ 保持 ]。
- [ 设置所有固定值通道 ]，即失控时，将设为固定值的所有通道设置为当前通道输出值。
- 可测试失控保护功能。可模拟模型失控后，发射机将关闭高频输出，模型进入失控状态，所有通道按失控保护设置输出。

## 测试失控保护功能

模拟模型失控后，发射机关闭高频输出，模型进入失控状态，所有通道按失控保护设置输出。

功能设置：

1. 点击 ，系统弹出操作提示。长按  超过 1 秒，系统切断高频输出。此时接收机按失控保护设置输出通道值；
2. 放开  后即恢复通信。

## 失控保护判断时间

用于设置失控保护判断时间。设置范围为 250ms~1000ms。默认 300ms。

功能设置：

1. 点击 [ 失控保护判断时间 ] 进入设置界面；
2. 点击 [ + ]/[ - ] 设置时间，点击  返回上一级界面。

## i-BUS & PPM 信号无输出

此失控保护设置是针对 i-BUS 和 PPM 信号。此功能开启后，不管各通道失控保护如何设置，这两类信号失控保护始终为无输出；未开启时，失控后按各通道设置：固定值或者保持最后输出值。系统默认开启状态。

点击 [ i-BUS/PPM 无输出 ] 右侧的图标 ，取消后，当模型丢失信号后对应的 i-BUS/PPM 信号无输出。

## 设置单独通道

分别设置通道 1~18 输出信号状态：[ 未设置（无输出）]：未设置失控保护值，失控后无信号输出；[ 通道值无输出 ] 表示表示无信号输出；[ 保持 ] 表示失控时保持输出最后通道值；[ 固定值 ] 可以通过移动控件来设置失控保护输出值。

功能设置：

1. 选择需要设置的通道，进入子菜单；
2. 选择合适功能项；若选择固定值，则将手轮（扳机或旋钮）拨到需要的位置并保持，同时点击返回图标即完成设置。

## 设置所有固定值通道

用于设置所有已经设置为固定值的通道失控后的输出值。

点击此功能项后，同时将控件拨到需要的位置并保持，在弹出的提示菜单“设置所有失控保护为固定值的通道失控保护值为当前输出值，确定？”，点击 [是] 即完成。



注意

- 为保证安全，请用户在使用前预先设定好失控保护值

## 舵机响应速度

此功能用于调节通道输出控制舵机频率，该功能包括模拟舵机（95Hz）、数字舵机（380Hz）、自定义频率，可根据使用的舵机选择或设置正确的输出频率值，系统默认数字舵机，自定义频率调节范围在 50-400Hz 之间。

连接不同的接收机，舵机响应速度的功能略有不同。

### 连接经典版接收机

功能设置：

1. 点击进入 [ 舵机响应速度 ]；
2. 根据需要选择点击对应功能项，点击 ◀ 返回上一级界面；  
若发射机高频设置选择 [AFHDS3 单向]，修改舵机响应速度，点击 ▶ 将弹出提示“对码或重新对码后生效，是否对码？”
3. 若选择 [ 自定义 ]，请点击屏幕“+”或“-”进行频率值调节。



## 连接增强版接收机

[SR]: 舵机响应速度中的一种规格 (PWM 频率为 833HZ)。

[SFR]: 舵机响应速度中的一种规格 (PWM 频率为 1000HZ)。

[与高频同步]: PWM 输出与 (RF) 无线信号接收的时序同步。

注: 常规的舵机响应速度 (即 PWM 的频率) 是 50-400Hz, 当选用 SR、SFR 时整个系统的延时会减小, 请确保适配的舵机支持对应的频率的, 否则可能导致舵机无法正常工作, 甚至损坏舵机。



### 设置单独通道

设置各通道的舵机响应速度。

功能设置:

1. 点击进入 [ 舵机响应速度 ];
2. 点击 [ 方向: 数字舵机 ] 或其他选项进入功能设置界面;
  - 点击 [ 与高频同步 ] 右侧的勾选框, 图标将会变为 , 勾选后此功能的舵机响应速度将同步至高频。
3. 根据适配接收机的实际情况选择点击对应舵机响应速度选项, 点击  返回上一级界面;

### 设置所有通道

设置所有通道的舵机响应速度。

功能设置, 参考设置单独通道的功能设置部分。

**!** 模拟舵机 (95Hz)、数字舵机 (380Hz) 为市场上较通用舵机频率值, 故单独设定以使用户快捷操作, 为使舵机正常运行, 请先查阅舵机使用说明书确认舵机正确频率, 然后通过该功能更改舵机频率数值。

## 固件更新

此发射机的内置软件程序能够通过使用 Micro USB 线与 windows 计算机连接后进行软件更新升级。一旦此功能被激活后，发射机所有功能将停止工作。为了防止车辆失去控制，请在进入此功能前断开接收机电源。



**警告**

- 请使用原厂的 Micro USB 线
- 当固件正在更新时请勿断开 Micro USB 线
- 电脑无法识别发射机连接时请检查电池底座是否接触良好

### 更新步骤：

1. 下载并打开最新的官方固件；
2. 通过 Micro USB 线先将发射机连接至电脑；
3. 点击主界面  图标，进入功能菜单界面，点击 [ 系统设置 ] 功能；
4. 点击 [ 固件更新 ]，弹出提示界面“更新固件可能会导致模型数据恢复成出厂默认值 是否更新？”，点击 [ 是 ] 即可进入更新模式。
5. 电脑端，点击 [Update] 后开始更新。
6. 更新完成后，发射机将会自动退出更新状态，并重新开机。（断开 Micro USB 线连接，并关闭电脑更新固件）



**注意**

- 系统更新完成后可能会导致接收机无法连接，此时需要更新高频与接收机

## 更新高频

### 更新步骤：

1. 点击主界面  图标，进入功能菜单界面；

2. 选择进入 [ 模型设置 ], 点击 [ 高频设置 ] 进入设置界面, 点击 [ 更新高频 ], 在弹出的提示界面点击 [ 是 ] 后, 界面弹出更新进度条, 等待几秒后更新完成后发射机自动退出更新界面。

**注:** 如发射机无法进入更新高频状态, 可能是无高频模块或高频模块故障。

## 更新接收机

接收机固件更新可以通过对码已建立连接且内置了接收机固件的发射机更新; 或者通过与发射机建立连接的“富斯遥控管家”完成更新。

### 功能设置:

1. 点击 [ 更新接收机 ]
2. 选择接收机后, 点击 [ 更新 ], 进入更新后, 进度 100% 时, 更新成功。

**注:** 1. GMr 等一部分接收机需使用“富斯遥控管家”进行更新, 请在富斯官网下载“富斯遥控管家”。

2. 如果接收机与发射机已经对码成功, 并且建立连接, 如接收机为最新版本, 则弹出提示 [ 当前版本已是新版本, 无需升级! ]。若发射机为旧版本, 则弹出提示 [ 确定将接收机更新吗? ]。弹出提示框后选择“确定”, 点击 [ 升级 ] 即可将接收机更新;

3. 如果接收机与发射机未建立连接, 则进入选择接收机界面, 勾选需要连接的接收机之后弹出提示 [ 请连接 XX 或使 XX 进入强制更新模式 ], 点弹出提示框后选择“确定”, 点击 [ 升级 ] 进入更新状态!

若更新接收机时, 如无法与发射机对码建立连接, 则需要手动强制更新接收机固件。

### 接收机进入强制更新模式

可通过两种方式使接收机进入强制更新状态:

- 按下对码键, 上电 10 秒后指示灯三闪一灭, 松开对码键;
- 先给接收机上电, 长按对码键 10 秒后指示灯三闪一灭, 松开对码键。

注：不同接收机进入强制更新状态方式不同，请参考具体接收机的说明书。

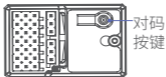

FGr8B

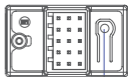

FGr4B 对码按键

## 对码

本发射机和接收机在出厂前已对码成功。如果您需要重新对码时，请按照如下步骤进行对码：

1. 开启发射机，点击主界面  图标并进入 [接收机设置]，点击 [对码设置]，根据实际使用的接收机，在弹出的菜单里选择 [经典版接收机] 或 [增强版接收机]（若选择增强版接收机，选择是否双接收机模式，并设置起始通道），点击 [开始对码]，发射机进入对码状态；
2. 使接收机进入对码状态；
3. 当接收机 LED 指示灯变为常亮时，对码成功；
4. 检查发射机、接收机是否连接正常。如有异常，重复以上步骤重新对码。

### 注：

1. 当选择单向通信时，接收机不回传数据信息给发射机，接收机收到对码信息后指示灯慢闪；需手动将发射机退出对码状态，接收机指示灯变为常亮表示对码成功；
  2. 富斯 AFHDS 3 经典版接收机型号：FTr10/FGr4/FGr4S/FGr4P/FTr4/FTr16S；其他富斯 AFHDS 3 接收机均为增强版接收机；
  3. 如需使用双接收机模式，点击 [双接收机模式] 右侧勾选框，图标变为  后，发射机将进入双接收机模式。选择后，请依次将发射机与主接收机和副接收机进行对码。
- 此步骤适用于 Noble Pro 与 FGr4B 及 FGr8B 的接收机对码，如您使用的是其他接收机，请进入官网查询对应接收机的使用说明书进行操作。

## 规格参数

### Noble Pro

适合模型	车、船、机器人、铁甲
通道个数	2( 极速 )/4 /6/8/10/12/18 可选
无线频率	2.4GHz ISM
发射功率	< 20dBm
RF 标准	AFHDS 3
低电压报警	< 3.65V
数据接口	Micro USB
充电方式	Micro USB + 无线充
天线类型	内置单天线
输入电源	1S / (4.2V) 锂聚合物电池 + 18650 双电池
固件更新	支持
遥控距离	>300m (不带支架)
外形尺寸	120*144*274mm
机身重量	670g (含手机支架)
认证	CE, FCC ID: N4ZFG400, MIC, RCM

本快速操作指南中的图片和插图仅供参考，可能与实际产品外观有所不同。产品设计和规格可能会有所更改，恕不另行通知。

*Figures and illustrations in this QSG are provided for reference only and may differ from actual product appearance. Product design and specifications may be changed without notice.*



微信公众号



Bilibili



Website



Facebook

FCC ID: N4ZFG400

出版日期 : 2025-05-12

Copyright ©2025 FLYSKY Technology Co., Ltd.



Manufacturer: ShenZhen FLYSKY Technology Co., Ltd

Address: 16F, Huafeng Building, No. 6006 Shennan Road, Futian District, Shenzhen, Guangdong, China